

Cant turner CT-25

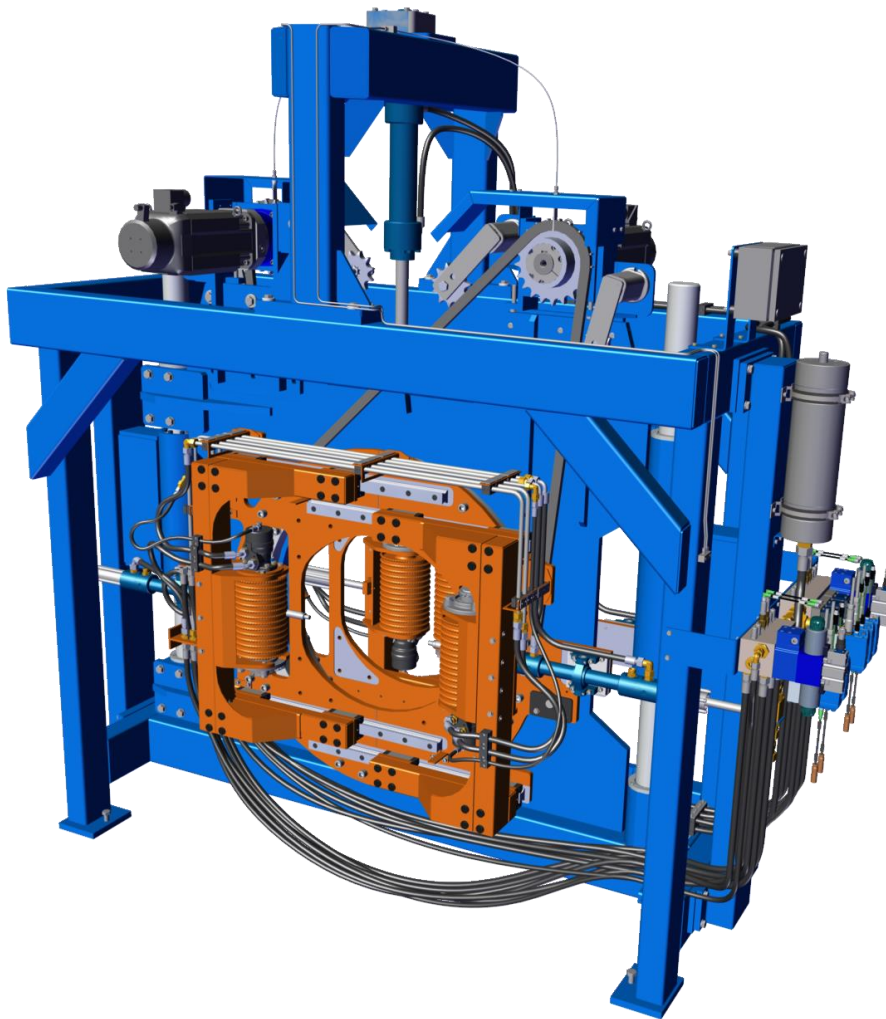

- ✓ Double block-laying rotors
- ✓ Higher capacity
- ✓ Higher speed



The cant turner CT-25 can be equipped with one or two separate cant turning rotors.

Each rotor consists of two hydraulically driven rollers, which grip the cant via servo-hydraulic cylinders and turn it during transport. Rotation of the rotor takes place via an electric servo motor

The center of rotation is adjustable and adapted to the current cant dimension via guide systems and servo-hydraulic cylinders.



CT-25



- For cant turning 90° of two-sided and four-sided reduced cants.

Measure:

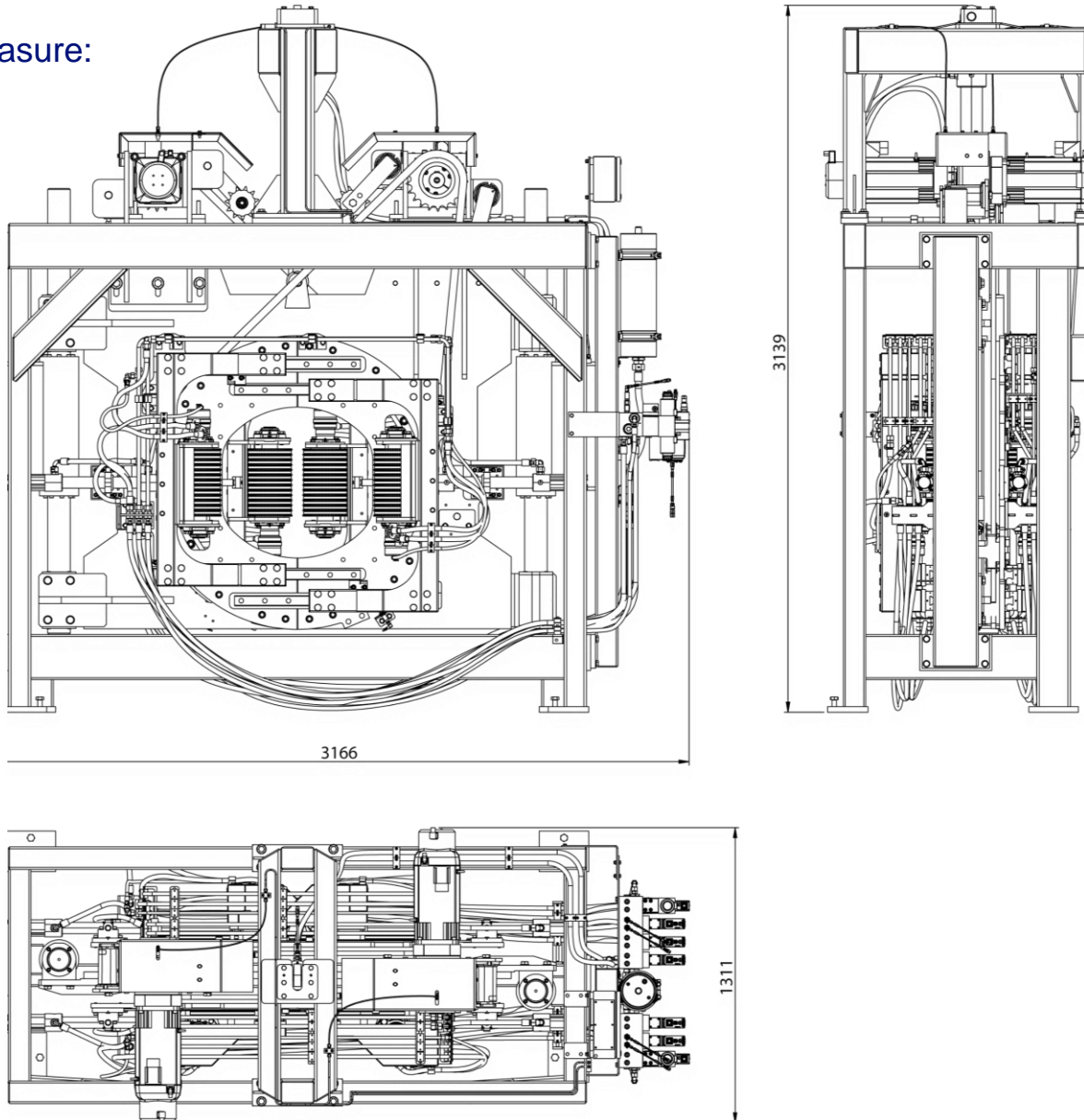

Tekniska data

Max feed speed.....	200m/min
Min log length	2 m
Min log hatch.....	ca 0,3 m
Max / Min log diameter enclosed	600/100 mm
Capacity.....	approx. 50 pcs/min
Weight.....	ca 4,5 ton

