

Cantinfeder CI-300

For optimized curve sawing or stright.

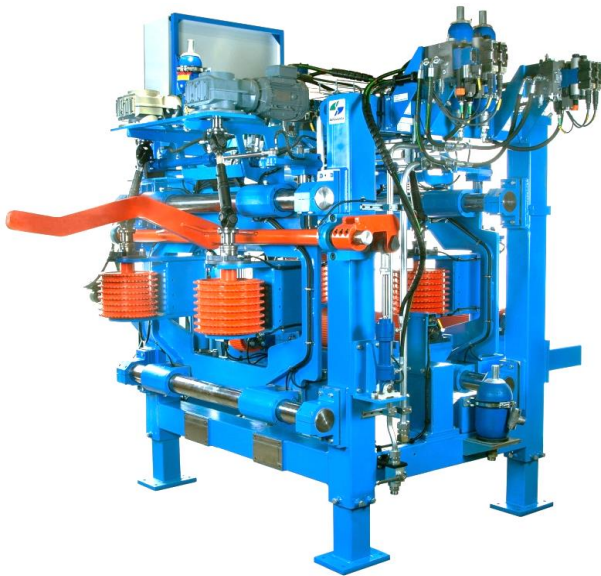

- ✓ Increased yield
- ✓ Higher quality
- ✓ More precise alignment
- ✓ Higher availability



CI-300S

Infront of 2nd Chipper canter



CI-300S

Infront of 2nd Chipper canter

Facts about optimized curve sawing

The 3D optimization calculates the result to achieve the best form after the chipper canter. The cant is handled active in **CI-300S** which side position the cant "online" through the canter. This gives the absolute highest recovery.



CI-300

CI-300 har drift via kardan på de drivna valsar vilket ger bättre åtkomst vid service men även lägre massa att förflytta vid snabba rörelser i höga hastigheter.



Dimension

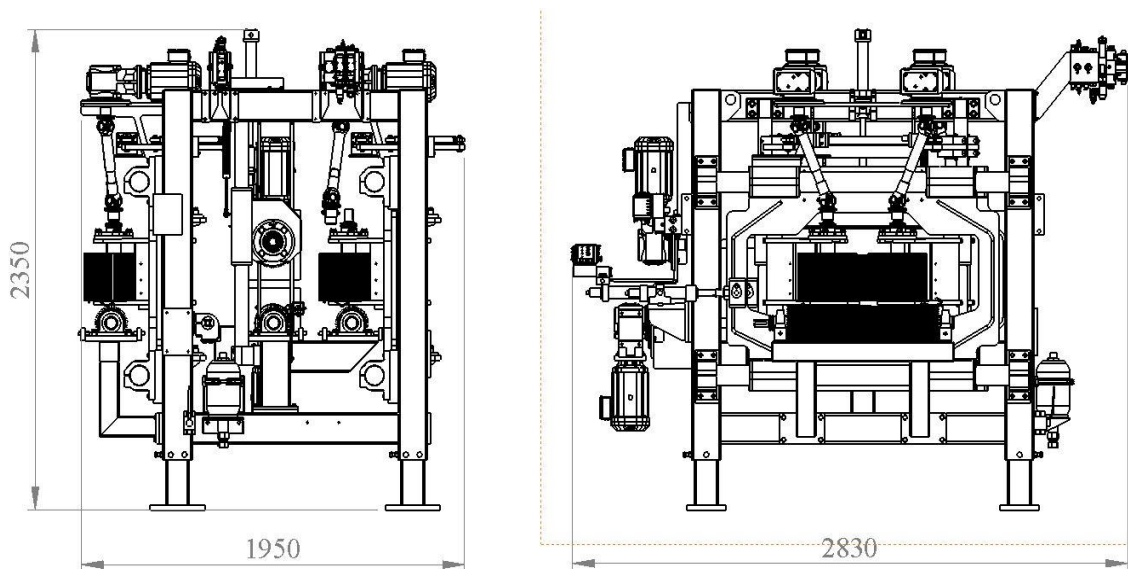

Technical data

Max Feed speed.....180 m/min
Min length..... 1,7m
Min log gap.....ca 0,3m

CI-300S

Max / Min log diameter envelope.....600/100 mm

CI-300C

Max / Min cant height..... 300 /50 mm
Max / Min cant width..... 550/ 70 mm

Weight.....approx 4 ton

