

Sawcommander QSS-300C



QSS-300 is a double-arbor circular saw that can be placed as a rotary gang saw, close coupled with chipper canter or as a free standing with centring feedwork. The QSS-300 is developed for today's and the future's increased demand on economy, high efficiency, availability, service friendliness and easy maintenance. QSS-300 is built on a heavy steel frame to ensure vibration free sawing with high cutting accuracy.

The QSS-300 is developed for both straight- and sweep sawing.

The centring feedwork has driven rollers placed just in front of the sawblades. Four shifting saws gives possibility to saw 5 pieces. All sawblades are fully settable down to 18 mm.

Horizontal adjustment of the top arbor saw is possible during operation.

QSS-300 has 4 shafts on which the sawblades are mounted. The motors run on linear guide systems for both vertical and horizontal movement.

Setting can be done both by hydraulic, or electrical servo.

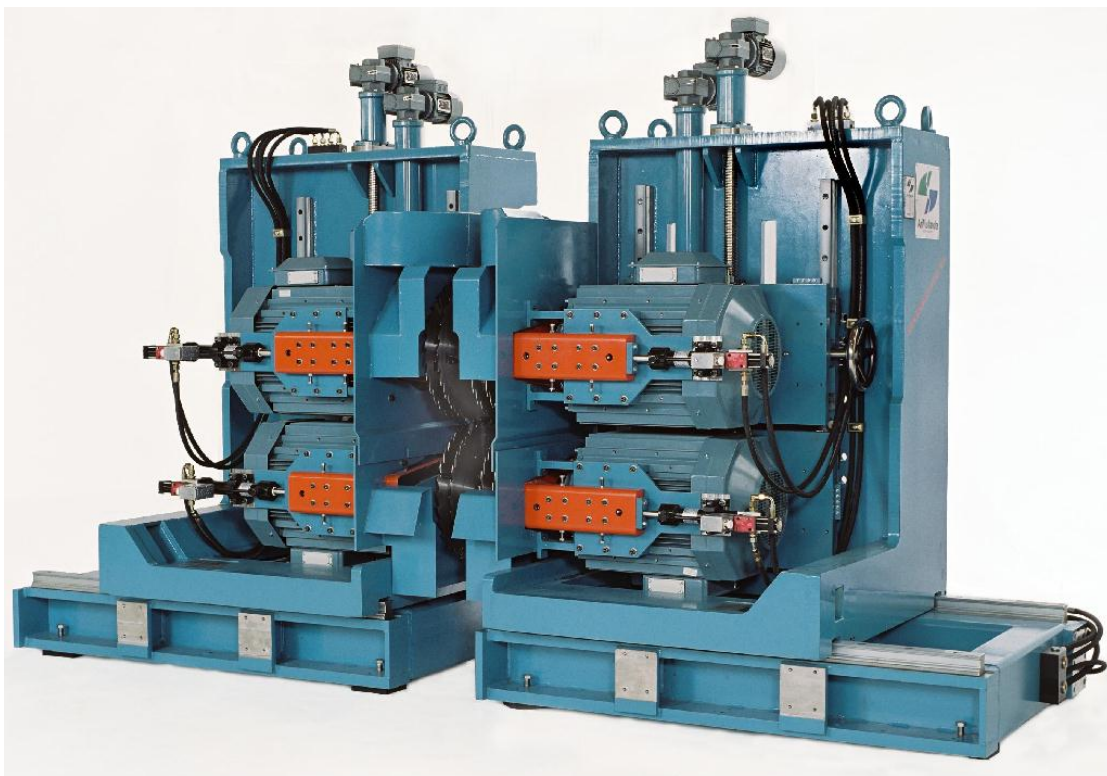

Dimensions

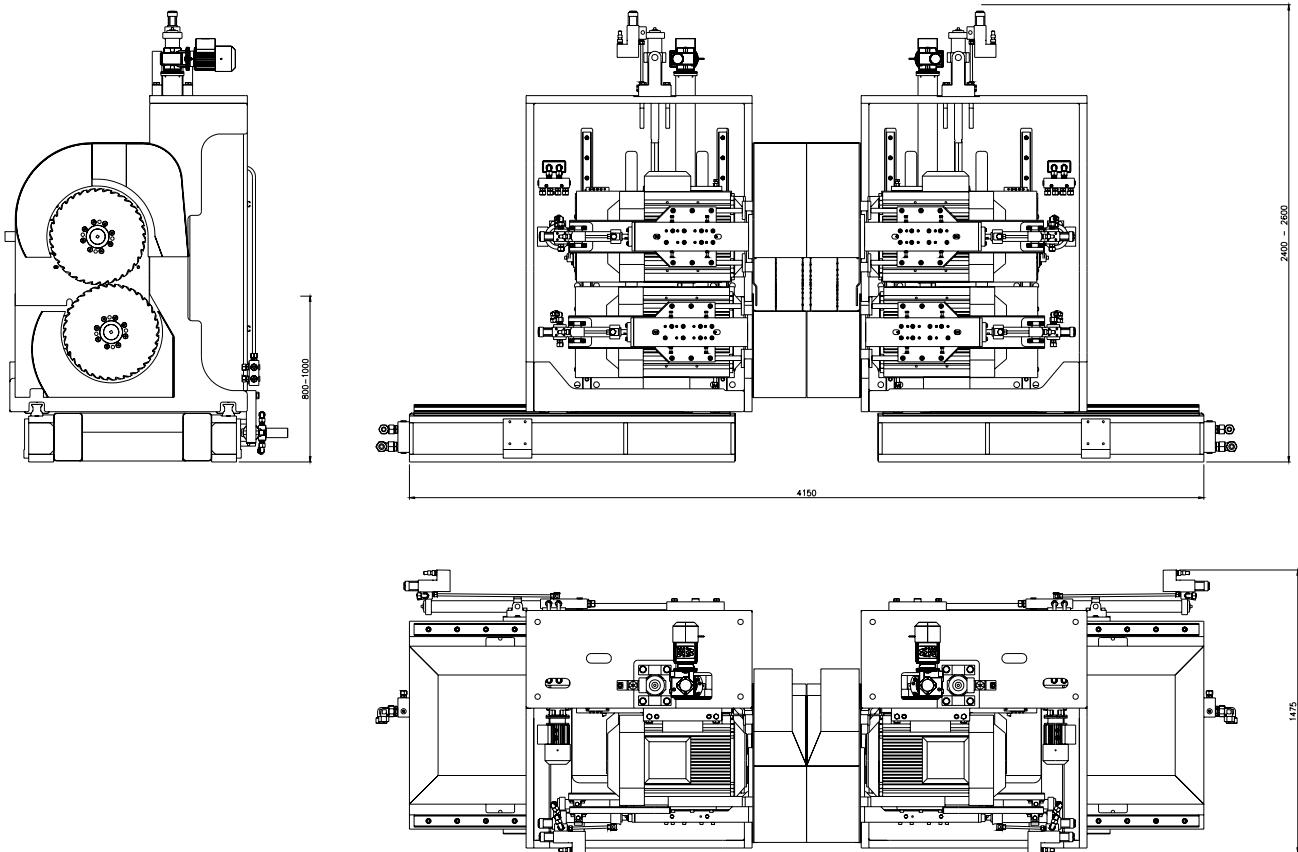

Technical data

Max feed speed	180 m/min
Max cant height	300 (400) mm
Sawblade diameter	480-570 mm
Distance between inner- outer sawblades	18-90 mm
Max opening between inner sawblades	1200 mm
Power requirement 2-4 sawblades	4x 55-95 kW
Rpm saw arbor	3000 rpm
Weight	ca 12 ton

We reserve the right to make changes



Adress
AriVislanda AB
Box 80
340 30 VISLANDA

Adress
AriVislanda AB
Box 249
891 26 ÖRNSKÖLDSVIK

Phone, Vislanda
+46 472 343 45
Fax, Vislanda
+46 472 343 49

Phone, Ö-vik
+46 660 868 00
Fax, Ö-vik
+46 660 199 22

E-mail
info@arivislanda.com
Homepage
www.arivislanda.com