

Rotary gang DS-74+1



Suitable for curve sawing

DS-74+1 is a single spindle rotary gang designed for break down of two or four sided cants. The machine has been delivered to more than 50 sawmills and is one of Ari's most appreciated sawing machines.

The famous design with a short cutting zone and guiding with centring and curve sawing rollers gives a high curve sawing accuracy. Accordingly the machine is very suitable for curve sawing.

Easy maintenance

A large, easy to open, service door makes the maintenance easy with quick tool changes.

Flexible and exact

The fence is designed with setworks to give full flexibility in the setting of four settable blades and one fixed blade in the centre. Floating blade centre and saw guides in the leading edge gives a very high dimension accuracy.

The saw guides are air/water /oil cooled with separate adjustable flow for each sawblade or sawblade cluster which gives longer working periods of both sawblades and sawguides

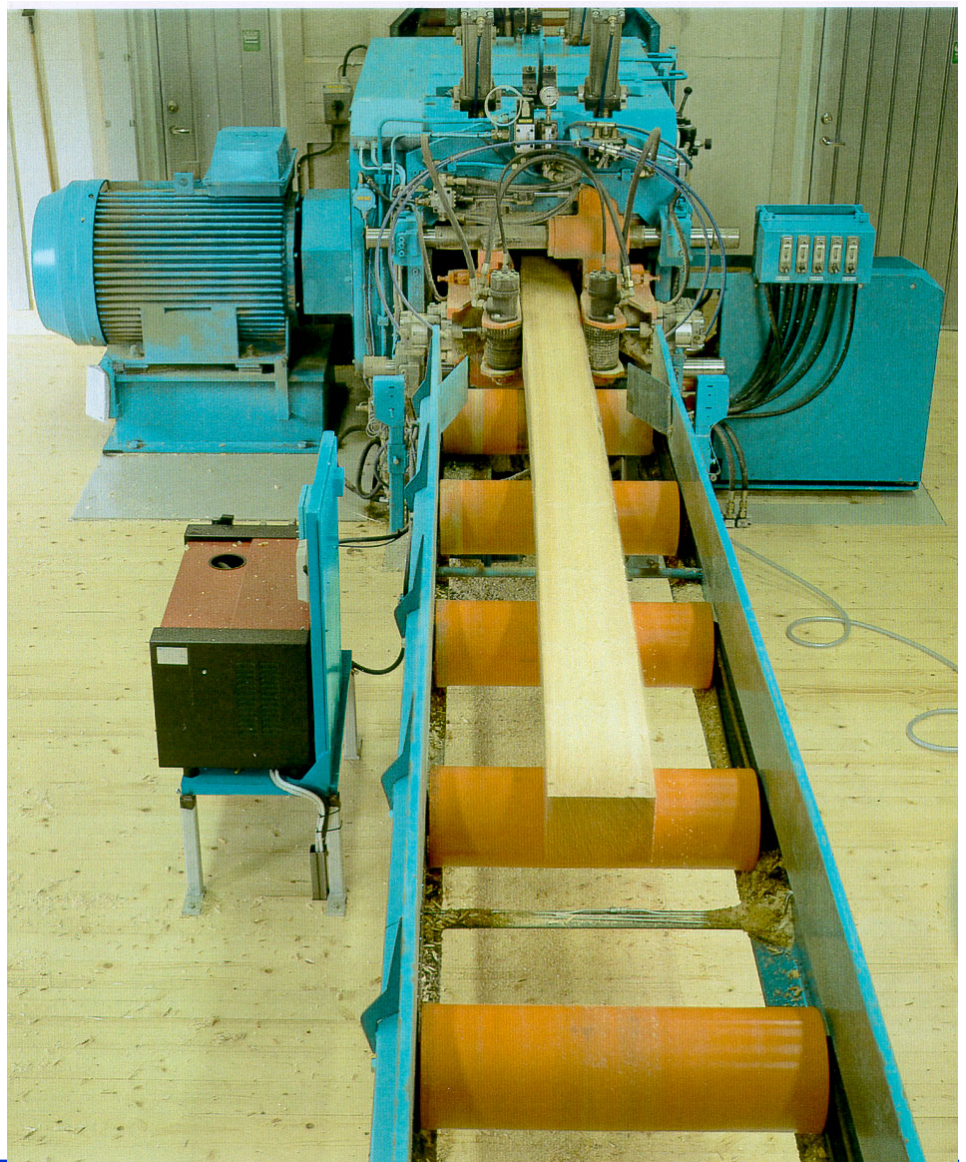

Dimensions

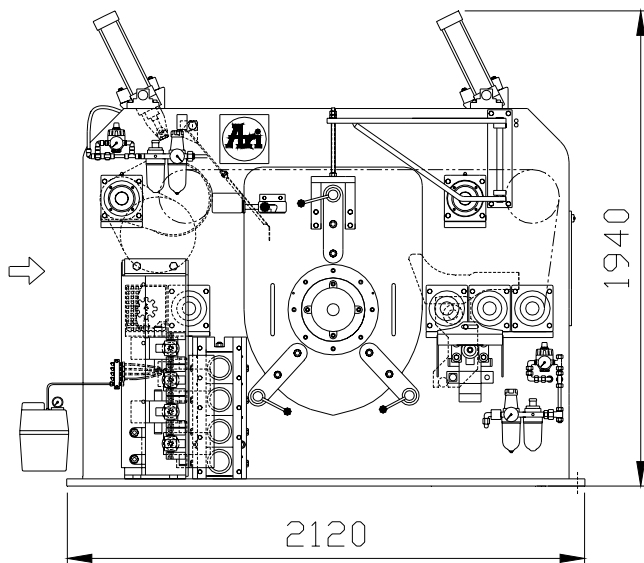

Vy uppifrån

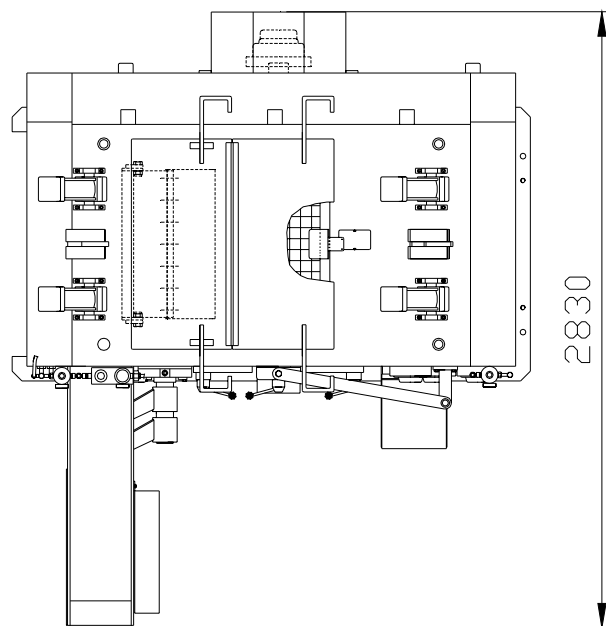

Technical data

Feedspeed up to 120 m/min
 Min. cant height 60 mm
 Max. cant height (recommended) 260 mm
 Infeed opening, width 700 mm
 Max. sawn dimension between the outer
 saw blades 395 mm
 Min. sawn dimension between the outer
 saw blades 25 mm*
 Min. sawn dimension between settable saw blade
 and fixed mounted saw blade 19 mm*

Saw blades

Number of settable blades 4
 Saw blade diameter 700 mm
 Blade width/kerf 2.6-2.8/3.8–4.0 mm
 Water consumption per saw blade
 (4.5 bar) 0.2 l/min
 Air consumption per saw blade
 (4 bar) 200 l/min
 Networks hydraulic servo

Power requirement

Spindle motor, 1500 rpm 160–315 kW
 Feed work 11 eller 11.5/8.5 kW

Weight, exclusive motors 4.8 ton

*Dimensions are nominal i.e. excluding allowances for shrinkage

Accessories

- Riving knives
- High pressure rinse of the sawguides (required with 25 mm between settable saw blades)

 **AriVislanda**
 SORB INDUSTRY

Address
 AriVislanda AB
 Box 80
 SE-340 30 VISLANDA

Address
 AriVislanda AB
 Box 249
 SE-891 26 ÖRNSKÖLDSVIK

Phone, Vislanda
 +46 472 343 45
 Fax, Vislanda
 +46 472 343 49

Phone, Ö-vik
 +46 660 868 00
 Fax, Ö-vik
 +46 660 199 22

E-mail
 info@arivislanda.com
 Web
 www.arivislanda.com

We reserve the right to make changes