

# Chipper canter SKR-600



**AriVislanda**  
SORB INDUSTRY

## Valuable basic machine

SKR-600 is a robust chipper canter, designed for reducing logs. More than one hundred deliveries makes it to one of AriVislanda's most purchased products.

The machine fulfils high requirements for performance, environmental demands and long service life and produces high-quality chips. SKR-600 is suitable to use in front of a band saw or a circular log edger.

## Small overall dimensions

The chipper canter is compact with small overall dimensions which makes it very suitable for existing sawlines and small saw buildings.

## Profitable edging

The chipper heads are available in two versions, with four or six knives, and gives very high chip quality. The choice of head is based on feed-speed and desired chip length. The chipper head is delivered with pre- or post cutting saw blades with carbide or Stellite teeth. These alternatives give the ability to adjust the sawn finish to the markets demands.

The sawblade can easily be changed during normal tool changes. The chipper is delivered with hydraulic positioning servo for settings. Electric servos are an alternative.

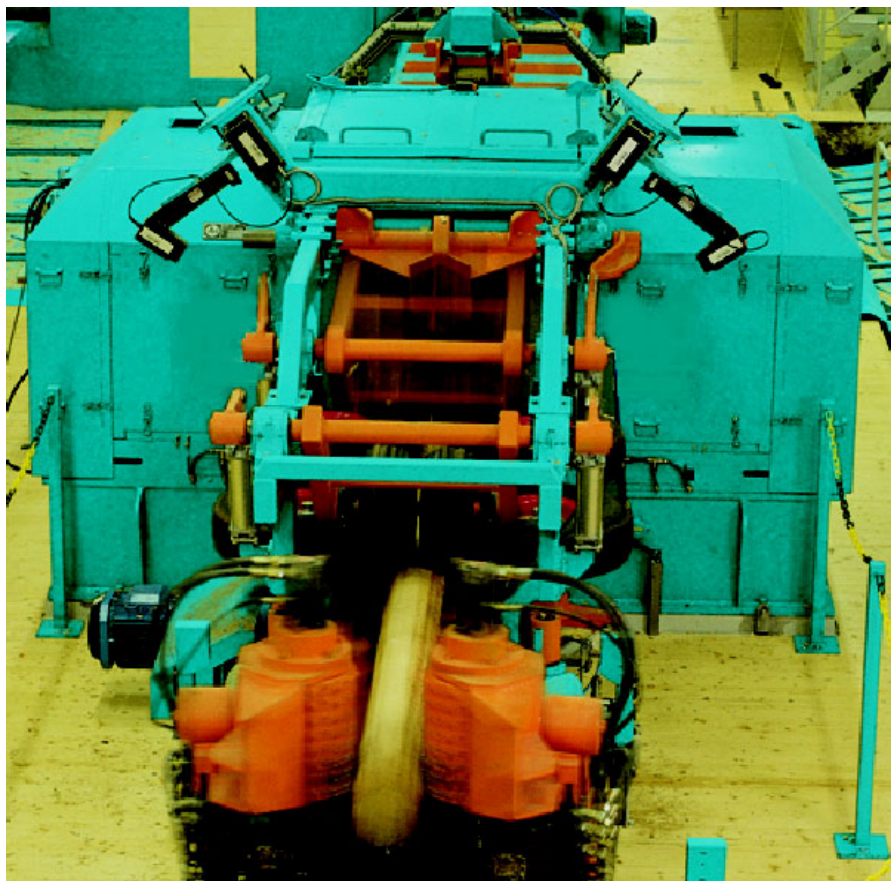

## Stable feeding

A powered underlying chain is feeding the log through the machine while a pressure rail ensures that the log is lying stable on the chain.

The standard equipment includes accessories and special equipment for normal maintenance.

## Dimensions

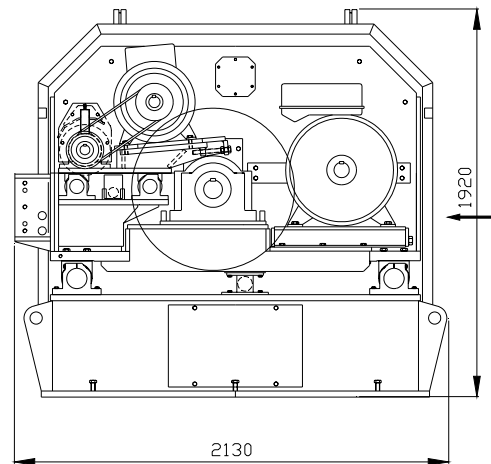
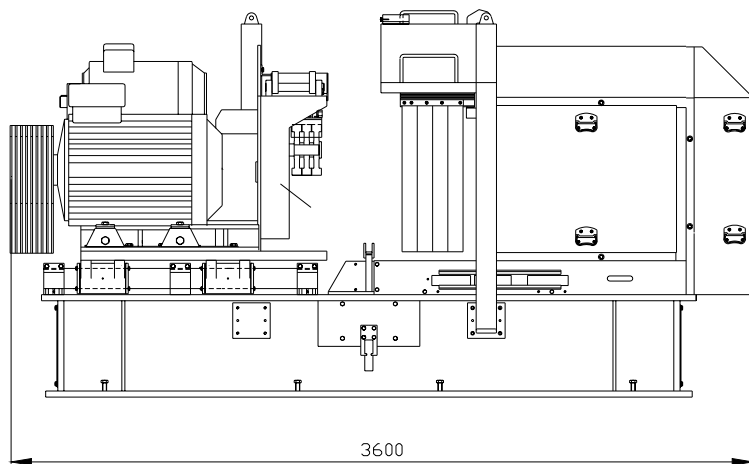

## Technical data

Max. feedspeed ..... 120 m/min  
Max. log diameter ..... 650 mm  
Min. log length ..... 2.5 m

### 4-knives head

Feedspeed at frequency control of the revolution and chip length 21 mm ..... 33–76 m/min

### 6-knives head

Feedspeed at frequency control of the revolution and chip length 21 mm ..... 50–114 m/min

### Chipper head

Max. cutting depth ..... 195 mm/side  
Max. height of cut above infeed level .... 575 mm  
Setworks ..... hydraulic servo  
Setting range, standard ..... 70–470 mm  
Revolution range ..... 400–900 rpm  
Number of knives per head ..... 4 or 6

## Power requirement

Spindle motors, 1483 rpm ..... 75-110 kW  
Hydraulic unit, setting ..... 4 kW

Weight ..... 9.5 ton

## Accessories

- corner cutter which allows smaller sawblade dimensions alternatively larger logs
- driven outfeeding rollers
- anvils for merry-go-round installations
- "Centro" which automatically centres the log top end and increases the infeeding accuracy and centre yield

 **AriVislanda**  
SORB INDUSTRY

We reserve the right to make changes

Address  
AriVislanda AB  
Box 80  
SE-340 30 VISLANDA

Address  
AriVislanda AB  
Box 249  
SE-891 26 ÖRNSKÖLDSVIK

Phone, Vislanda  
+46 472 343 45  
Fax, Vislanda  
+46 472 343 49

Phone, Ö-vik  
+46 660 868 00  
Fax, Ö-vik  
+46 660 199 22

E-mail  
info@arivislanda.com  
Web  
www.arivislanda.com