

# Sawcommander QSS-700L



QSS-700 is a double-arbor circular saw, that has a unique L-design and can be placed as primary breakdown machine after a log chipper canter. The QSS is developed for today's and the futures increased demand on economy, high efficiency, availability, service friendliness and easy maintenance.

QSS-700 is built on a heavy steel frame to ensure a vibration free sawing with high cutting accuracy.

The feedwork has driven roller and guide plate, placed just in front of the sawblades.

The machine is equipped with limit cutters to protect the saw arbors.

Possible to saw up to 4 sideboards, fully settable.

Adjustment of the top arbor saw is possible during operation.



QSS-700 has 4 shafts on which the sawblades are mounted. The motors runs on linear guide systems for both vertical and horizontal movement.

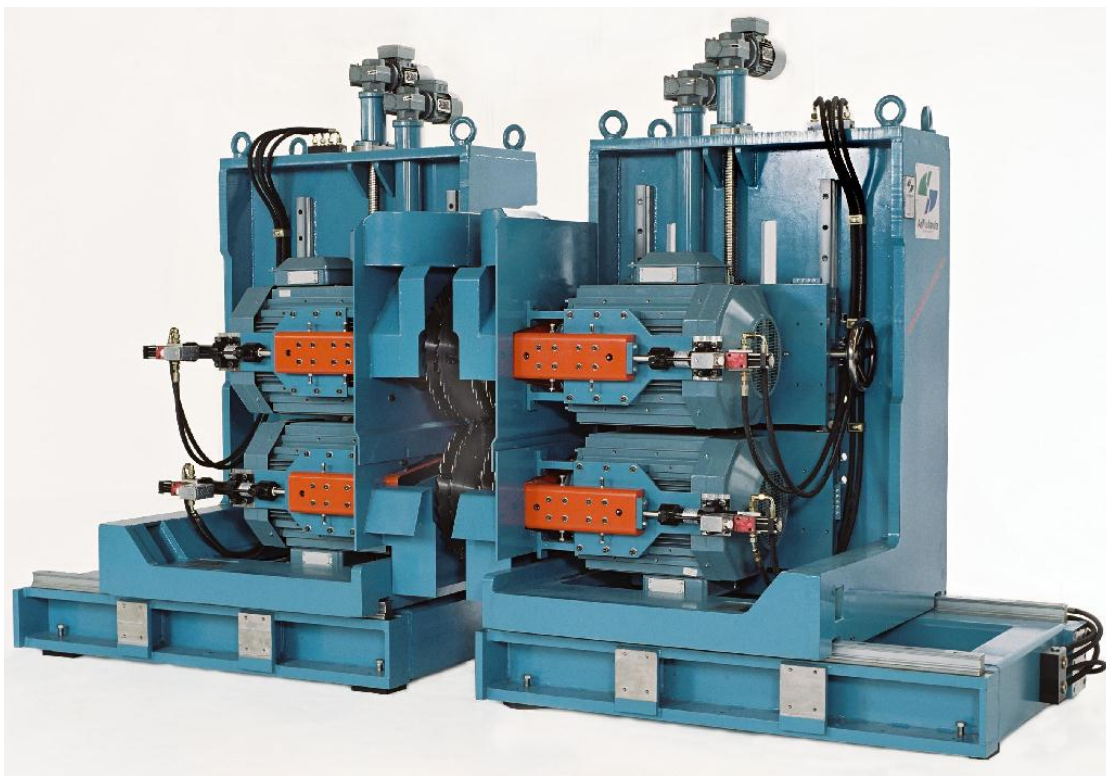

## Dimensions

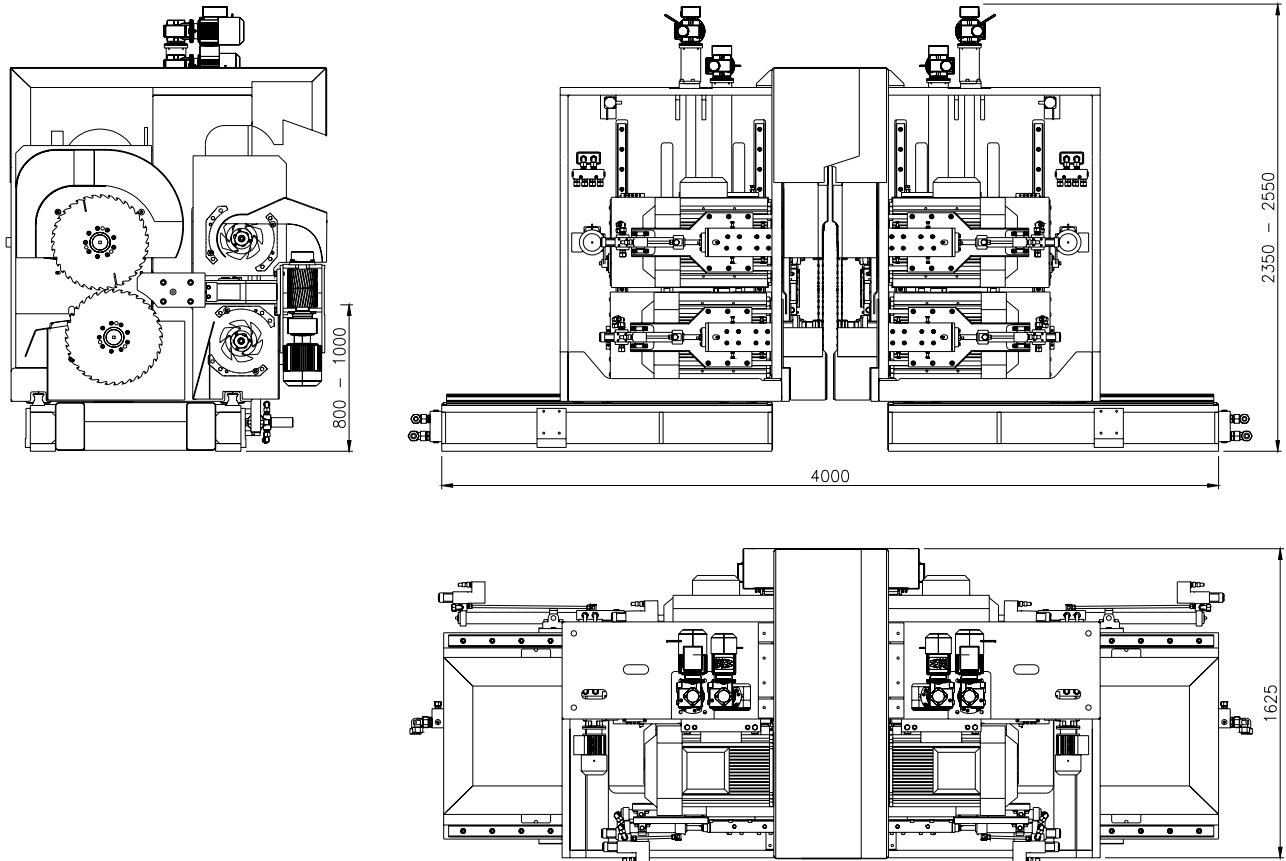

## Technical data.

Max feed speed .....	180 m/min
Max log diameter .....	700 mm
Max sawing height (above feed level) .....	550 mm
Sawblade dimension .....	480-570 mm
Min distance between inner- outer sawblades .....	18 mm
Max opening between inner sawblades (service position) .....	1200 mm
Power requirement 2-4 sawblades .....	4x 55-95 kW
Power requirement limit cutters .....	4x 30-45 kW
Rpm saw arbors .....	3000 rpm
Rpm limit cutters .....	3000 rpm
Weight .....	14 ton

We reserve the right to make changes.



Adress  
AriVislanda AB  
Box 80  
340 30 VISLANDA

Adress  
AriVislanda AB  
Box 249  
891 26 ÖRNSKÖLDSVIK

Phone, Vislanda  
+46 472 343 45  
Fax, Vislanda  
+46 472 343 49

Phone, Ö-vik  
+46 660 868 00  
Fax, Ö-vik  
+46 660 199 22

E-mail  
info@arivislanda.com  
Homepage  
www.arivislanda.com