

Circular headrig KS-122/124



Robust and enclosed

KS-122/124 is designed for sawing of boards after the primary chipper canter. The numbers 122 and 124 stand for saw blade $\text{\O}1200$ mm and 2 respectively 4 saw blades.

AriVislanda has delivered more than 50 KS-122/124 which has, thanks to few moving parts, a very high availability and long working life. The machine is enclosed against noise and dust.

High dimensional accuracy

The saw blades have floating centre and are equipped with sawguides. The design minimises the oscillations in the sawblade and gives a high dimensional accuracy. The guides also facilitate quick dimension settings.

The saw blade has an extra long working period thanks to air/water/oil cooled saw guides. The mixing unit for air/water/oil with separate

adjustable flow for each sawblade or sawblade cluster is included.

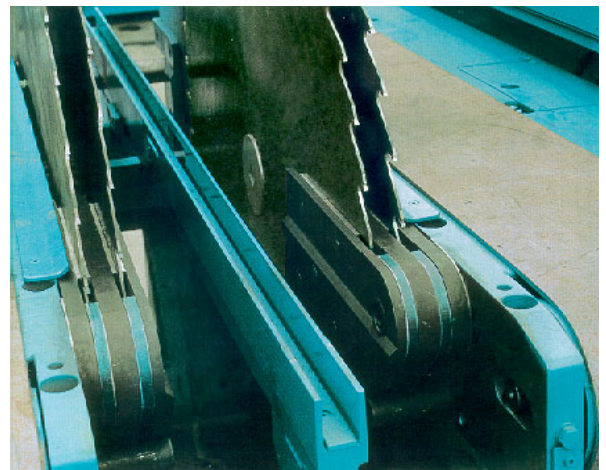

Saw guides

To increase the working period additionally floating rear sawguides (Floatex) can be installed. Floatex decreases oscillations in the sawblade and gives high availability.



Stable feeding

The feeding is performed with a sharp chain through the machine.

Slabs or sideboards are transported by hydraulic driven belts.

Dimensions

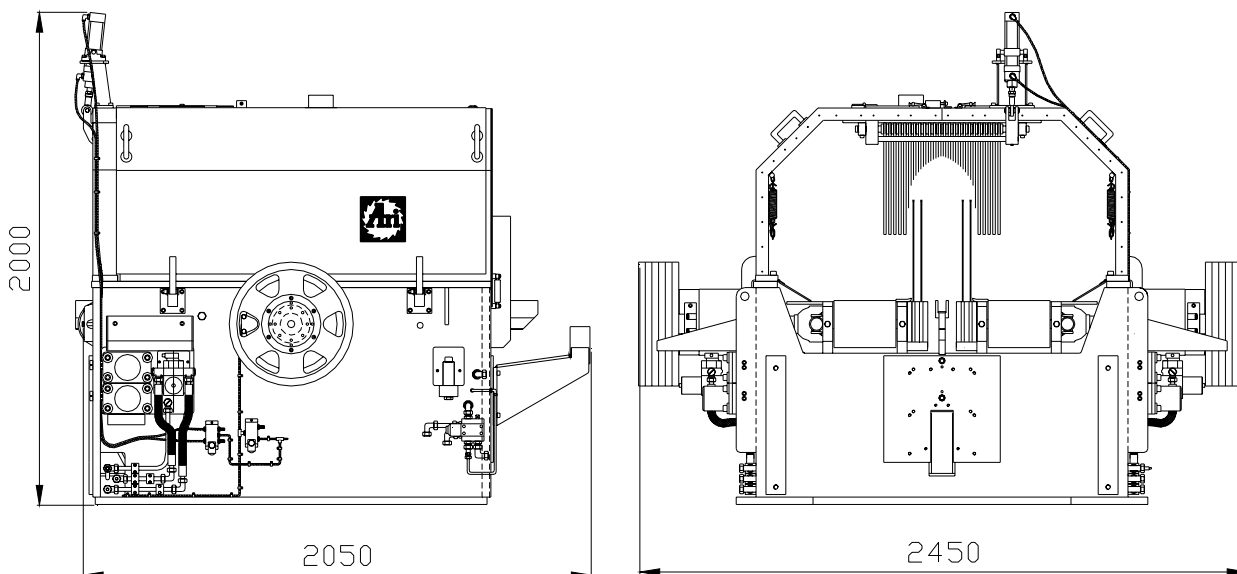

Technical data

Max. feedspeed 90 m/min
Max. log diameter (275 mm cant height) 550 mm
Min. log length..... 3.0 m
Max. cutting height..... 490 mm

Side boards (KS-124)

Inner (fixed) 19/22/25/32/38/44/47/50 mm

Saw blades

Number of sawblades..... 2 or 4
Saw blade diameter 1000–1200 mm
Blade width/kerf 5.0/3.6 mm
Water consumption pressure 4.5 bar
flow, KS-122 0.4 l/min
flow, KS-124 0.8 l/min
Air consumption pressure 6 bar
flow, KS-122 500 l/min
flow, KS-124 1000 l/min
Min/max distance between saw blades ..KS-122 75/330 mm
KS-124 75/275 mm

Power requirements

Spindle motorsKS-122 2x45/55 kW
KS-124 2x90/110 kW
Spindle rotation speed (1200 mm)..... 730 rpm

Saw guides

Saw guides..... 4+4 st outer saw guides with JM-wear plates
Setworks.....hydraulic servo

Weight..... ca 4 ton

We reserve the right to make changes



Örnsköldsvik
Phone: +46 660 868 00
Fax: +46 660 199 22

Vislanda
Phone: +46 472 343 45
Fax: +46 472 343 49

E-mail: info@arivislanda.com
Internet: www.arivislanda.com