

Hydraulic setting bar

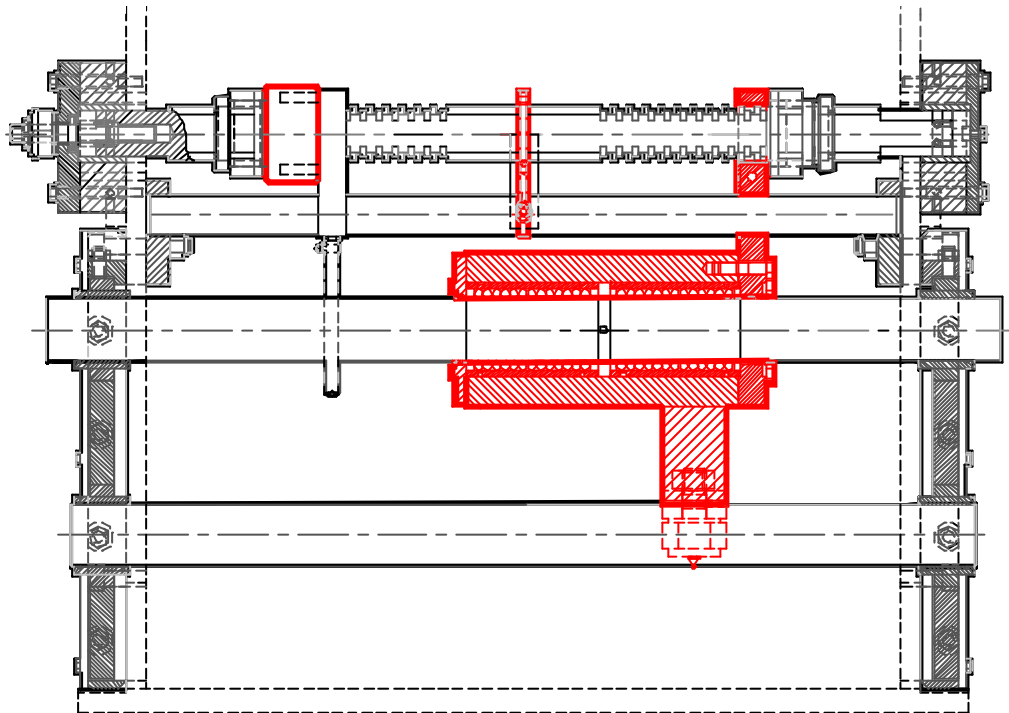

AriVislanda offers a new setting bar for fixed setted machines with hydraulic fastening of the guide-blocks to keep the dimensional accuracy.

The new hydraulic setting bar involves also shorter set-up time and a more stable fastening at the setting.

Fits all resaws model DS-50, DS-70, DS-79 och DS-80.

The setting bar has manuel fine adjustment.

A constant hydraulic pressure at 40-50 bar is needed.

Hydraulic unit, quoted on request.

The rebuilding-set includes

- stable reference arm to apply the setting against
- middle distance for connecting the cooling liquid to secure cooling to all guideblocks