

Increased accessibility reduces the cost

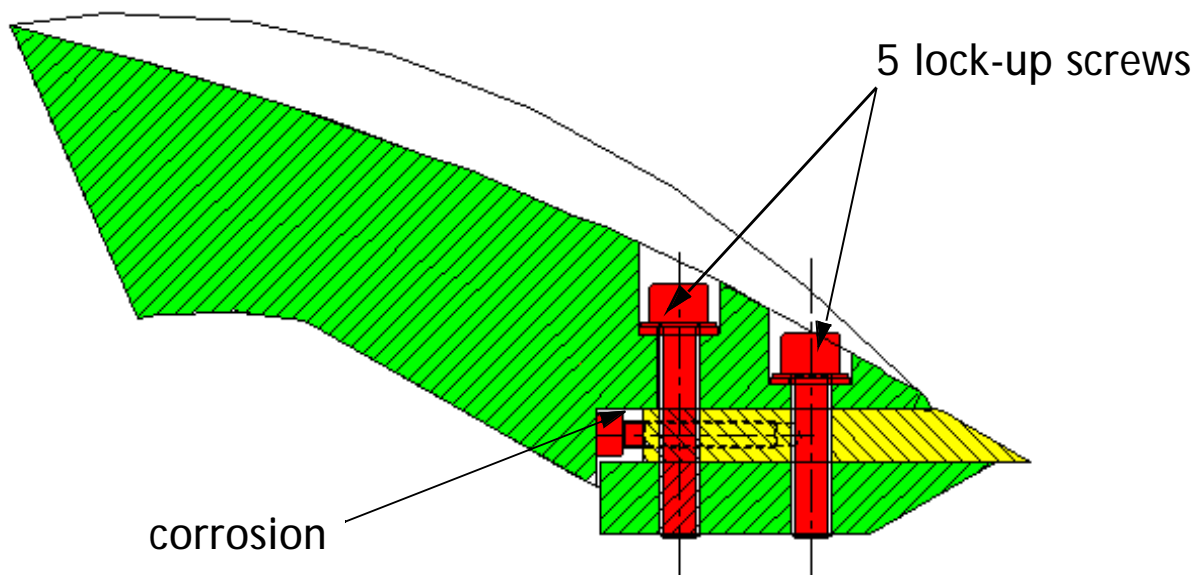

It has been known by inspections on the chipper heads that there has formed rust on the seats for the chipper knives.

The corrosion makes a heightening so that a loose between knife and the contact surface can be the result when changing knives that are different much grinded or changing to new knives. This can lead to defects on the chipper heads which can result in broken screws and the knives get loose.

To obstruct this it is important that the seats for the knives become cleaned at regular intervals, suitable as preventive service once a month. After cleaning and change of knives, the contact surface should be prepared with thin-boided slushing oil e.g. 5-56. The lockup screws and the washers should also be changed every 6.th month at 1-shift drive, to guarantee the strength.

With this discovery, we have introduced 2 extra lock-up screws on the new chipper heads, to increase the security. The screws are situated behind the existing ones, to give a more stabil lock-up of the knives. To additionally secure a good lock-up of the knives it is very important not to grind more than 25 mm of the knives, since it increases the risk to get damage on the chipper heads and knives get loose.

If you have questions and thoughts, please call us att AriVislanda After sales.